

# Comfortable casting technology



Your project  
is our main project

[www.italpressegauss.com](http://www.italpressegauss.com)

**ITALPRESSE | GAUSS**  
A Norican Technology

[www.italpressegauss.com](http://www.italpressegauss.com)

# Table of contents

TIMELINE AND HISTORY	04
HIGH PRESSURE DIE CASTING	06
GRAVITY DIE CASTING	10
LOW PRESSURE DIE CASTING	12
TURNKEY FULLY AUTOMATED CELL	14
ITALPRESSE GAUSS 4.0	16
SERVICE	17
FIELDS OF APPLICATION	18

# Timeline and History

One supplier for light alloy casting

Italpresse Gauss is a comprehensive supplier of light alloy casting equipment and automation solutions for three different die casting processes: high pressure, gravity and low pressure.

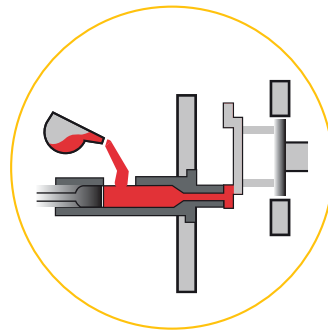

**01** High Pressure Die casting

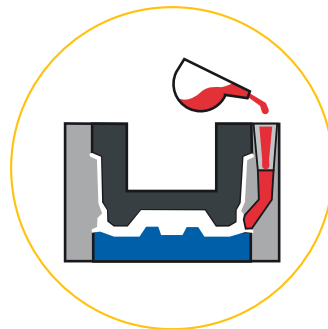

**02** Gravity Die casting

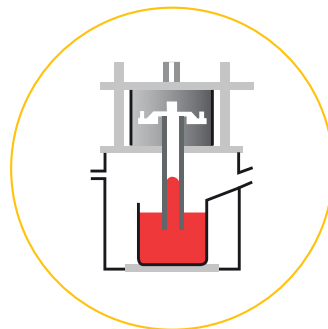

**03** Low Pressure Die casting

# Norican Group

## Shaping Industry

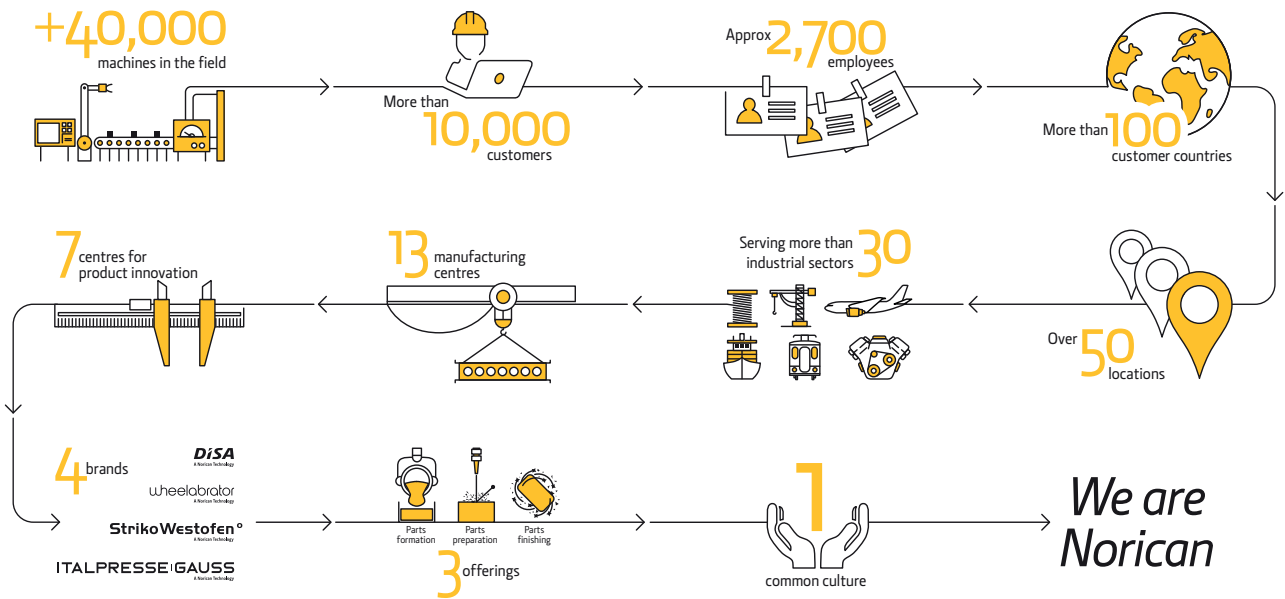

Together with you, we are shaping industry

Italpresse Gauss builds machines and automatic work cells for the light alloy casting, mainly for the automotive industry, with a focus on excellence, technological innovation, quality and production flexibility. The Company provides advanced solutions backed by 50 years of experience acquired worldwide and offers prompt and professional service to ensure optimum performance and durability of products, wherever they are. Italpresse Gauss is committed to increasing its leadership position and worldwide presence, by providing cutting-edge technological solutions.

Since its establishment in 1969, Italpresse Industrie has produced high-pressure machines and automatic work cells for the die casting of light alloys. It has been a technological leader in the industry since the 1970s with the introduction of foundry automation and with the development in 2005 of the two-platen machine. Gauss Automazione, established in 1967, supplies work cells for gravity and low-pressure light alloy die casting, mainly for the automotive industry.

Norican Group is home to four leading, globally operating brands: DISA, Italpresse Gauss (incorporating Italpresse Industrie and Gauss Automazione), StrikoWestofen and Wheelabrator. As one strong global partner, Norican Group is able to serve customers better, faster and more efficiently, giving easy access to all the four brands have to offer and working in partnership to keep customers well ahead of the curve. From melting, dosing and moulding through to surface preparation, Norican Group provides the solutions to solve customers' challenges.

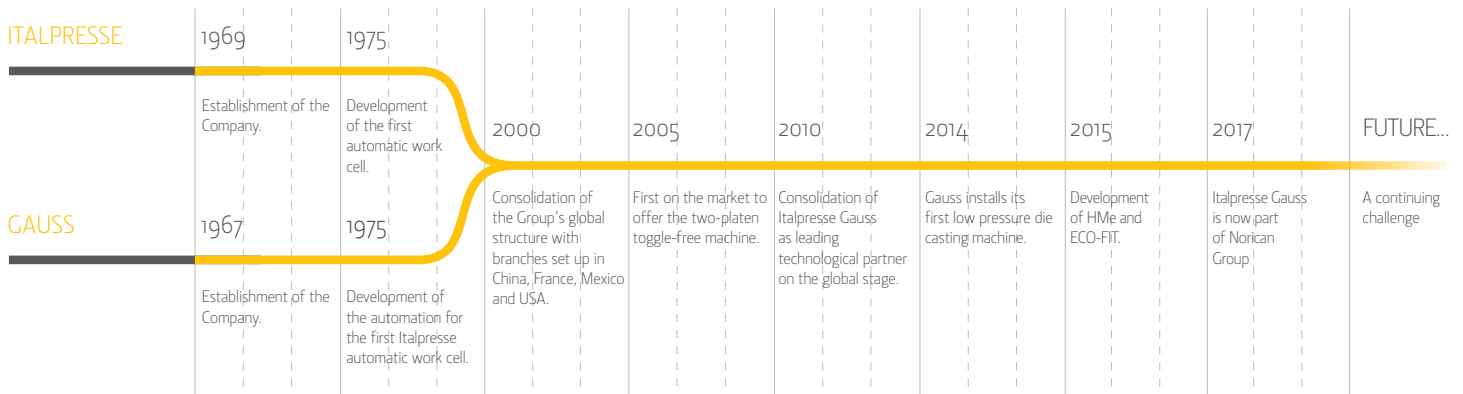

# High Pressure Die Casting / IP & IPr Series

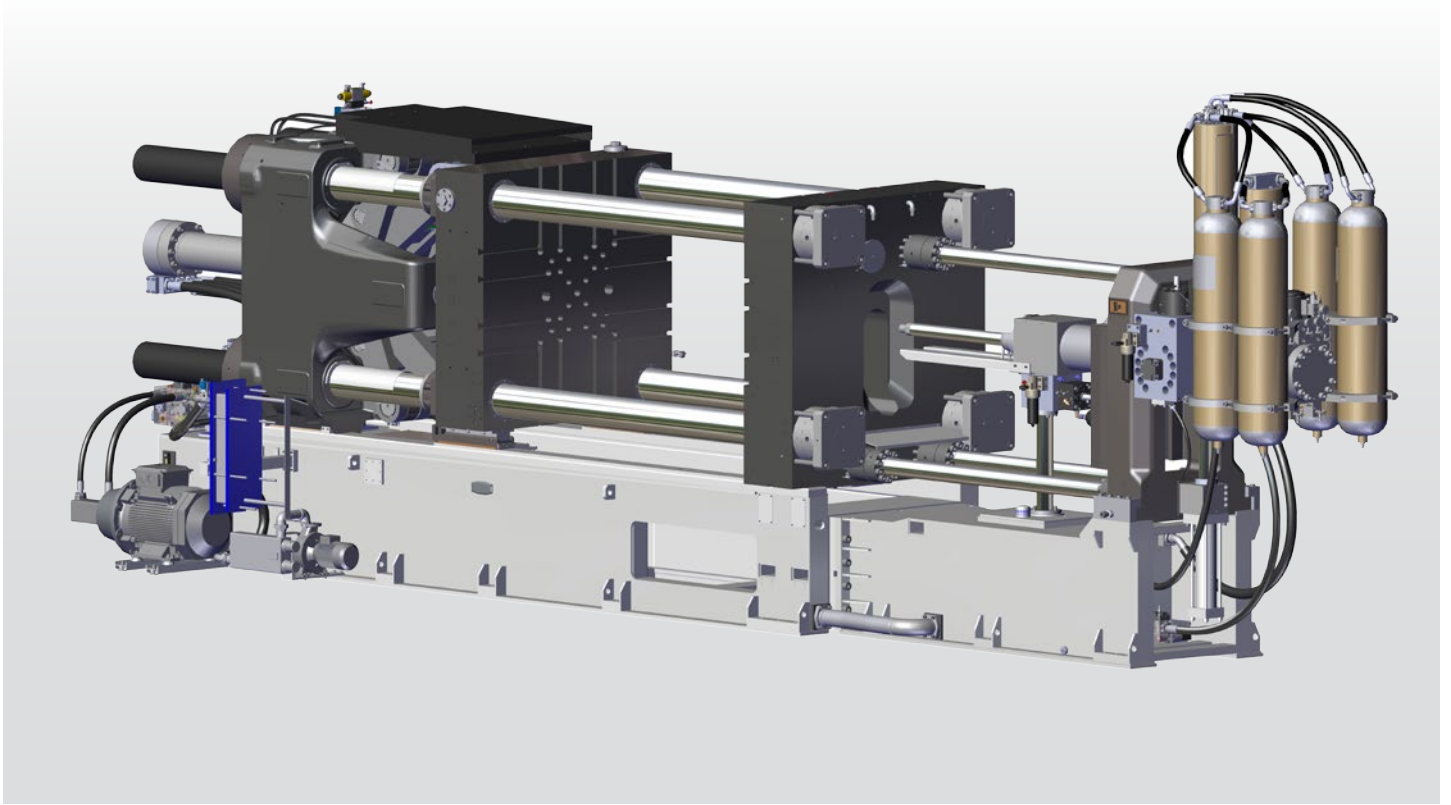

## Three platen machine with toggle

The three platen machine with toggle features the range's traditional consolidated technology. Thanks to 48 years of experience and worldwide usage, a wide variety of models is available with closing force ranging from 200 to 4400 tonnes.

- Focused on reliability and easy maintenance
- New hydraulics, modular and with flexible hoses
- Large platen and longer strokes in less space

In 2014, improvements were made to the three-platen machine and a new version was developed. The new series, the IPr, is inspired from the classic IP toggle machine offers larger platens and longer strokes in less space.

## Fully automated cell

The Three Platen Machine can be supplied with automation and peripheral devices: a FULLY AUTOMATED CELL that integrates all peripheral devices, from the furnace to automatic deburring with pieces ready for machining.

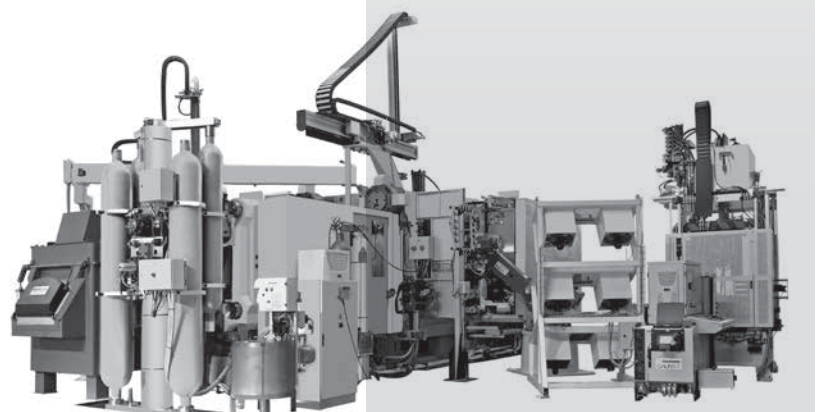

# Technical Data

	Series	Cold Chamber	Closing force	Injection force (with 0/25 bar backpressure)	Injection stroke	Platens dimensions	Distance between tie-bars	Min. /Max die height	Max. moving platen stroke	Ejection force	Central ejection stroke	Max. surface area (with pressure on metal 40 MPa)	Max. shot weight	Motor rating	Machine weight	Overall dimensions (L x W x H)
			kN	kN	mm	mm	mm	mm	mm	kN	mm	cm <sup>2</sup>	kg	kW	t	mm
SMALL SIZE	IP 200		1960	249 / 213	280	750 x 750	480 x 480	180/530	460	106	90	490	1.8	15	9.5	5210 x 1920 x 2040
	IP 300		2940	353 / 299	320	880 x 880	540 x 540	210/650	500	189	120	735	2.7	18.5	14.6	5920 x 2420 x 2550
	IP 400		3925	467 / 396	410	1010 x 1010	610 x 610	210/745	550	212	150	981	4.3	22	17	6680 x 2530 x 2580
	IP 550		5395	604 / 505	500	1075 x 1100	690 x 690	325/825	630	290	170	1349	7.9	30	24.1	7650 x 2720 x 2950
	IP 750		7360	710 / 619	575	1255 x 1265	775 x 775	385/940	750	369	180	1840	10.8	37	32.6	8560 x 3050 x 2885
	IP 900		9319	819 / 720	600	1400 x 1410	875 x 875	400/1000	850	486	200	2330	13.3	45	45	8705 x 3341 x 3030
MEDIUM SIZE	IP 1100		10790	1015 / 892	740	1500 x 1520	945 x 945	425/1040	950	486	220	2700	19	2 x 30	55	10100 x 3920 x 3540
	IP 1150	STD	11277	1025 / 924	750	1650 x 1650	1050 x 1050	400/1150	1000	486	220	2820	14.1	2 x 30	70	10130 x 4070 x 3580
		PLUS		1226 / 1105	850								21.8		75	
	IP 1350		13235	1150 / 1011	740	1650 x 1660	1010 x 1010	425/1150	1050	574	240	3300	21.8	2 x 30	75	10367 x 4054 x 3692
	IP 1450	STD	14219	1226 / 1105	850	1780 x 1780	1150 x 1150	400/1300	1200	579	260	3555	21.8	2 x 37	105	11300 x 4100 x 3860
		PLUS		1446 / 1303	950								28.0		110	
	IP 1650		16186	1294 / 1137	800	1780 x 1780	1130 x 1130	460/1210	1200	574	255	4047	23.6	2 x 37	95	11206 x 4330 x 4164
	IP 1750	STD	17161	1446 / 1303	950	1950 x 1950	1250 x 1250	450/1400	1400	579	260	4290	28.0	2 x 45	110	12000 x 4470 x 4350
		PLUS		1712 / 1541	1150								38.5		120	
	IP 1850		18148	1470 / 1298	900	1950 x 1950	1250 x 1250	550/1400	1300	574	280	4537	26.5	2 x 45	130	12760 x 4544 x 4425
	IP 2150		21090	1591 / 1392	1000	2100 x 2100	1330 x 1330	650/1500	1400	668	300	5237	37.8	2 x 55	160	13555 x 4680 x 4485
	IP 2250	STD	22064	1712 / 1541	1150	2200 x 2200	1400 x 1400	650/1600	1500	751	300	5516	38.5	2 x 55	150	14100 x 4550 x 4310
PLUS		1971 / 1774		1250	47.3								150		14350 x 4650 x 4650	
IP 2500		26485	1705 / 1505	1000	2230 x 2230	1430 x 1430	750/1650	1500	716	300	6621	42.4	2 x 75	176	14013 x 4810 x 4562	
IP 2750	STD	26967	1971 / 1774	1250	2450 x 2450	1550 x 1550	750/1800	1600	751	300	6742	47.3	2 x 75	220	15270 x 4750 x 4590	
	PLUS		2250 / 2025	1350								63.8		223		15460 x 4750 x 4791
IP 3000		32373	2135 / 1885	1250	2550 x 2550	1620 x 1620	800/1800	1600	996	325	8093	59.1	2 x 90	256	15441 x 4360 x 4710	
IP 3300	STD	32360	2250 / 2025	1350	2650 x 2650	1700 x 1700	800/2000	1700	1010	400	8090	63.8	4 x 45	240	16400 x 5050 x 4900	
	PLUS		2649 / 2384	1350								70.7		240		16500 x 5050 x 4900
IP 3500		36300	2818 / 2489	1250	2670 x 2670	1700 x 1700	900/2000	1700	996	350	9075	65.4	2 x 110	285	16320 x 4930 x 5840	
IP 3700	STD	36282	2649 / 2384	1350	2800 x 2800	1800 x 1800	900/2100	1800	1010	400	9071	70.7	4 x 55	250	17500 x 5250 x 5000	
	PLUS		2970 / 2673	1500								86.6		250		17800 x 5250 x 5200
IP 4400	STD	43164	2970 / 2673	1500	2900 x 2900	1850 x 1850	900/2300	1900	1063	400	10780	86.6	4 x 75	344	18245 x 6010 x 6000	

# High Pressure Die Casting / TF Series

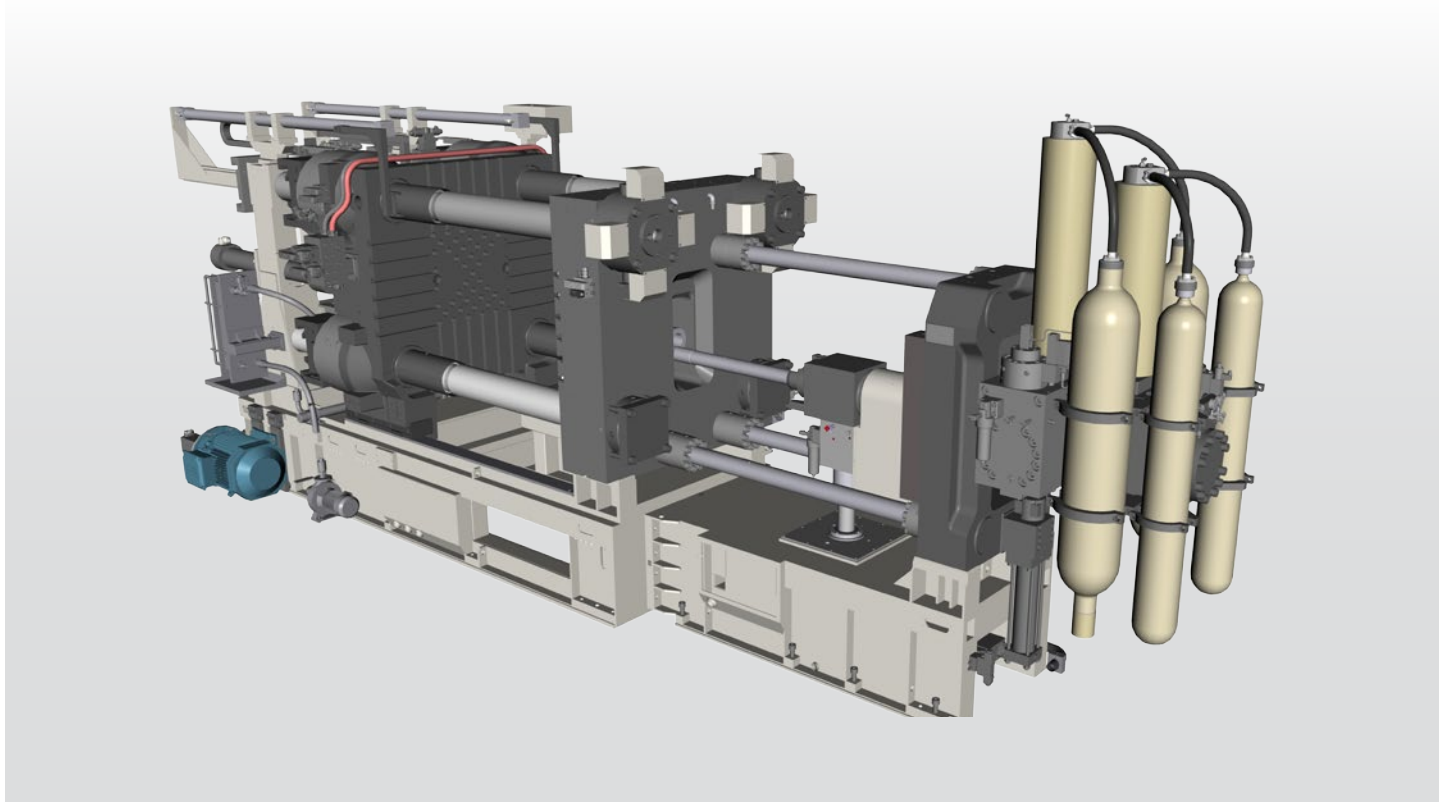

## Two platen toggle free machine

The two platen toggle free machine is compact, modern and efficient. The hydraulically driven closing force keeps the machine steady, ensuring the dies close better, thus reducing scrap. The machine automatically compensates for die parallelism issues and thermal expansion, making it suitable for operation in various working conditions.

- Optimisation of space
- Flexibility
- Reliability/maintainability
- Rational design

## Fully automated cell

The TF Machine can be supplied with automation and peripheral devices: a FULLY AUTOMATED CELL that integrates all peripheral devices, from the furnace to automatic deburring with pieces ready for machining.

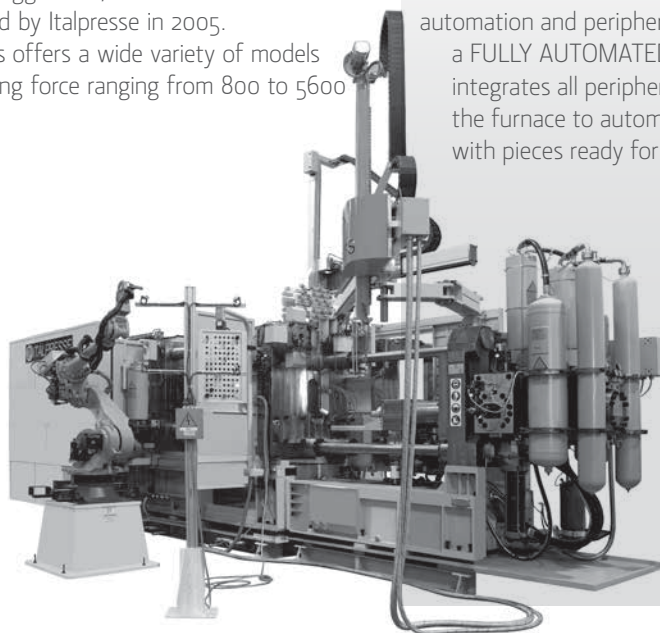



# Technical Data

Series	Closing force	Injection force (with 0/25 bar backpressure)	Injection stroke	Platens dimensions	Distance between tie-bars	Min. /Max. die height	Max. moving platen stroke	Ejection force	Central ejection stroke	Max. surface area (with pressure on metal 40 MPa)	Max. shot weight	Motor rating	Machine weight	Overall dimensions (length x width x height)
	kN	kN	mm	mm	mm	mm	mm	kN	mm	cm <sup>2</sup>	kg	kW	t	mm
<b>TF 800</b>	7848	761/699	575	1400 x 1400	815x815	490/940	1200	395	180	1960	10.8	45	34	8295 x 3250 x 3005
<b>TF 1000</b>	9810	1015 / 892	740	1520 x 1520	950 x 950	550/1000	1300	486	200	2450	19	55	48.5	9090 x 3460 x 3540
<b>TF 1350</b>	13243	1150 / 1011	740	1785 x 1785	1050 x 1050	600/1040	1400	574	240	3310	21.8	2 x 37	67	9225 x 4060 x 3750
<b>TF 1650</b>	16186	1294 / 1137	800	1960 x 1960	1150 x 1150	700/1150	1500	574	255	4040	23.6	2 x 37	96	9667 x 4320 x 4300
<b>TF 1850</b>	18148	1470 / 1298	900	2200 x 2200	1300 x 1300	800/1210	1650	574	280	4535	26.5	2 x 55	116	11120 x 4780 x 4690
<b>TF 2150</b>	21090	1704 / 1505	1000	2230 x 2260	1350 x 1350	900/1400	1800	716	300	5270	37.8	2 x 55	144.5	11775 x 4930 x 4685
<b>TF 2500</b>	24525	1704 / 1505	1000	2535 x 2535	1550 x 1550	900/1500	2000	716	300	6130	42.4	2 x 75	167	12140 x 5000 x 4947
<b>TF 2700</b>	26487	2135 / 1885	1250	2535 x 2535	1550 x 1550	900/1800	2450	716	300	6620	59.1	2 x 90	171	13611 x 5220 x 4910
<b>TF 3000</b>	29430	2135 / 1885	1250	2880 x 2880	1700 x 1700	1100/1650	2000	996	325	7355	59.1	2 x 110	216	14230 x 5400 x 5220
<b>TF 3500</b>	34335	2818 / 2489	1250	3060 x 3060	1780 x 1780	1200/1800	2100	996	350	8585	65.4	2 x 110	240	14780 x 5600 x 5830
<b>TF 4400</b>	43164	2818 / 2489	1500	3200 x 3200	1850 x 1850	1300/2000	2500	996	400	10780	78.5	2 x 160	296	15500 x 6000 x 5930
<b>TF 5600</b>	55000	3320/3040	1600	3500 x 3500	2000 x 2000	1400/2400	3300	1196	400	13750	110	4 x 90	350	17700 x 6500 x 6300

MEDIUM SIZE

LARGE SIZE

# Gravity Die Casting

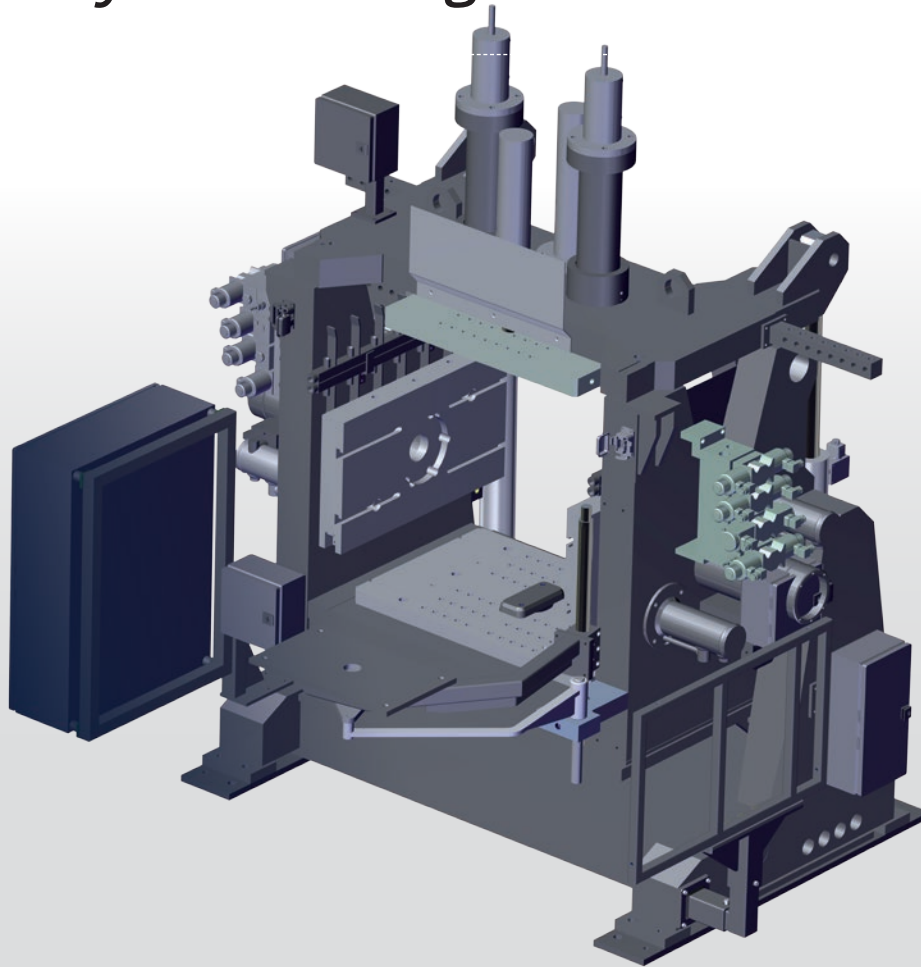

## Gravity die casting machine

- More than 50 types of machines for different dies.
- All machines differ in terms of:
  - Plate size (up to 1200x200);
  - Number of dies per machine.

## Gauss gravity die casting machines are classed as follows:

- Die horizontal opening machines
- Die vertical opening machines
- 0/90° Tilting machine controlled by hydraulic servo-valve, GT CAST-ID series
- 0/120° Tilting machine controlled by servomotor GT CAST-EL series

## Fully automated cell

Gravity die casting machines can be supplied in FULLY AUTOMATED solutions: carousel, linear cell or flexible cell. The Casting cells can be fully automated with Italtresse Gauss gantries or anthropomorphic robots and supplied with pre-finishing devices.



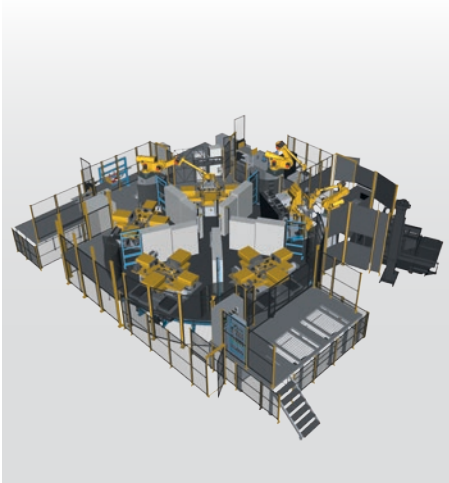

### Carousel

- Turntable: from 3 m to 12m
- Payload: from 2 tonnes to 90 tonnes
- Sectors for gravity casting machines: from 2 to 10
- Complete set of safety guards in accordance with European Law (CE)
- Absolute flexibility for the installation of any type of casting machine
- Very high production rate and minimisation of number of operators

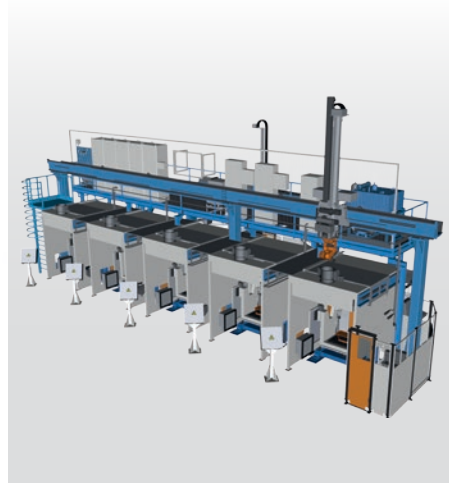

### Linear Cell

- Total length up to 24 m
- Cells: from 2 to 6 machines
- Complete set of safety guards in accordance with European Law (CE)
- Absolute flexibility for the installation of any type of casting machine
- Very high production rate and minimisation of die change times

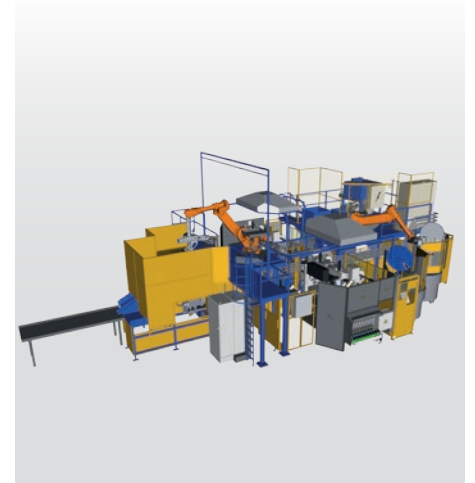

### Flexible Cell

- Made up of 1 or 2 gravity casting machines
- This solution has great flexibility when it comes to choice of automation
- It is especially suitable for small/medium production series. It is appreciated for the "investment modularity", an important feature for customers with a long ramp-up

# *Low Pressure Die Casting*



# LPG Series

Italpresse Gauss, a leader in the production of high-pressure and gravity die casting solutions, has developed a line of low-pressure die casting machines, the LPG series. This gives you the advantage of having a partner for 3 different light alloy casting technologies.

## Some important features

Rationalisation of the cooling system which runs using proportional electro valves and hydraulic blocks, all seated and grouped on top of the machine, with access stairs for easier maintenance.

- Large platen and furnace dimensions for multiple cavity dies
- Translation of the furnace on rails with auto lift and lock
- Tilting furnace to facilitate emptying and maintenance
- Casting removal device for complete automation

## Fully automated cell

Gauss Low Pressure Machines can be supplied with automation and peripheral devices: a FULLY AUTOMATED CELL that integrates all peripheral devices, from the furnace to automatic deburring with pieces ready for machining.

Technical data sheet	LPG 700	LPG 1000	LPG 1850
----------------------	---------	----------	----------

### Clearance between tie bars

Longitudinal	mm	1950	1950	2100
Transverse	mm	800	1000	1500
Moving platen stroke	mm	1300	1300	1500
Opening Force	kN	103	188	253

### Control system

Operator panel	Industrial PC	Industrial PC	Industrial PC
PLC	Siemens S7	Siemens S7	Siemens S7

# Turnkey Fully Automated Cells

## Solutions designed to suit your need

Italpresse Gauss supplies automatic work cells that integrate all peripheral devices, from the furnace to the automatic deburring. We offer flexible solutions with turnkey delivery of individual components, complete cells or the engineering process alone. We can carry out the design, realization, installation and start-up from feasibility studies, to design, assembly of the machine and all the peripheral devices including integrated control system.

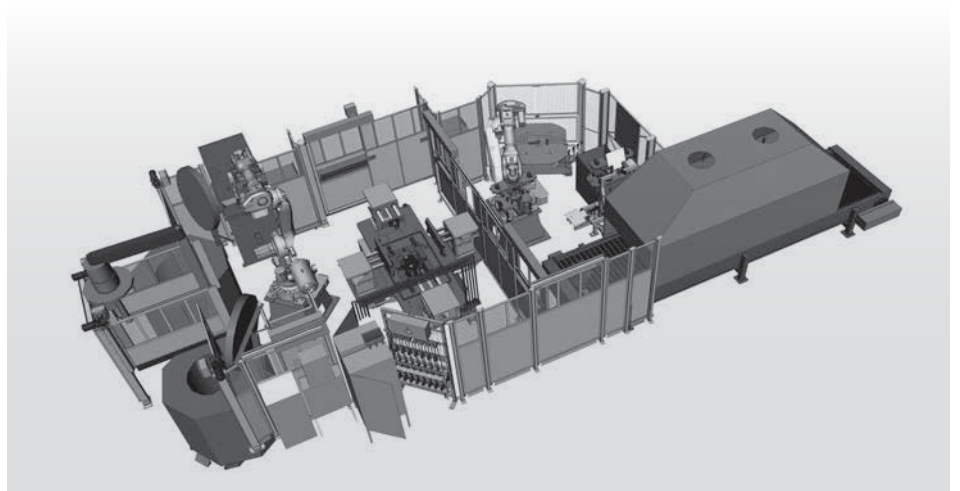
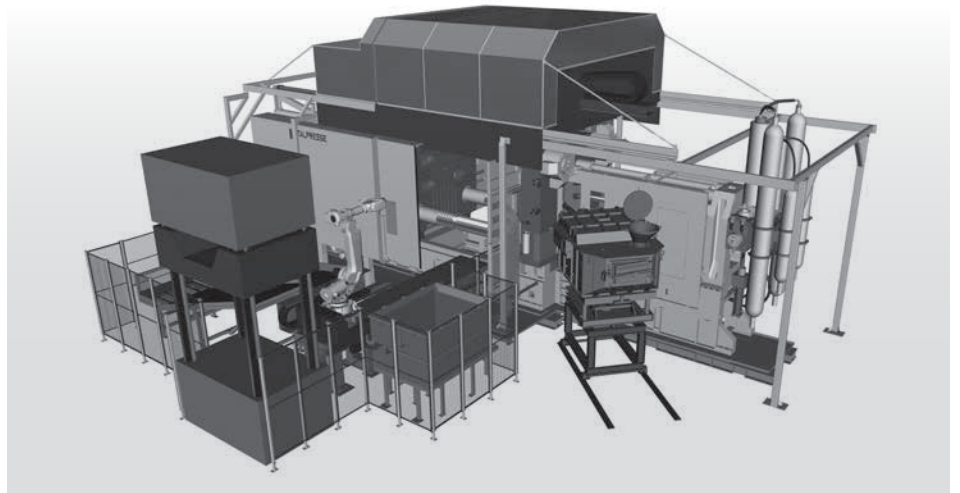
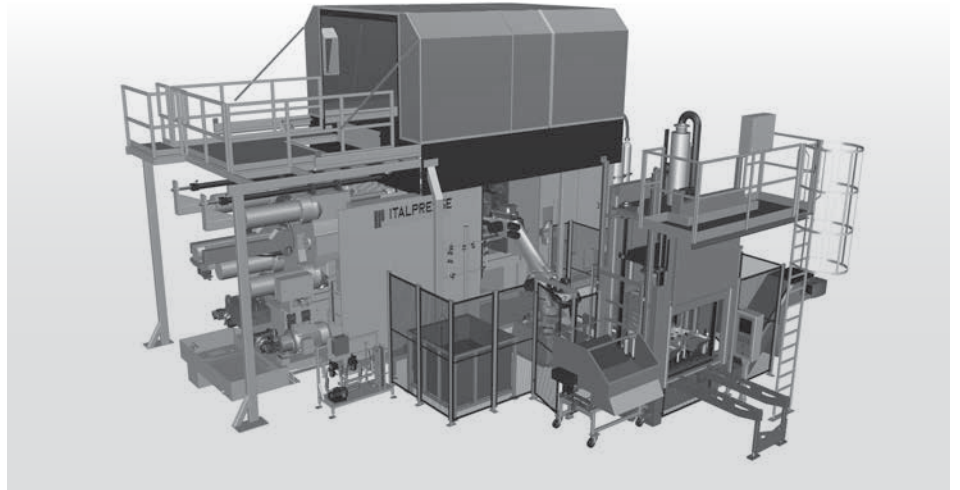

PROCESSES

	HPDC	GDC	LPDC
FURNACE	✓	✓	✓
DEGASSING	✓	✓	✓
AUTOMATIC CORE ASSEMBLY		✓	✓
CORE SETTING		✓	✓
INSERT HANDLING	✓		✓
POURING	✓	✓	
VACUUM	✓	✓	✓
EXTRACTION	✓	✓	✓
INTEGRITY CONTROL CHECK	✓	✓	✓
LUBRICATION/TALCING	✓	✓	✓
MARKING & MARKING CHECK	✓	✓	✓
PRE DECORING		✓	✓
COOLING (AIR/WATER)	✓	✓	✓
DECORING		✓	✓
CUTTING	✓	✓	✓
DEBURRING/TRIMMING/ HANDLING	✓	✓	✓
<i>...and other customisable options</i>			



# Italpresse Gauss 4.0



HMe is the user-friendly system developed by Italpresse Gauss for the supervision and control of machines.

HMe is powered by Wonderware, the global leading brand by Schneider Electric for industrial software including HMe and SCADA.

HMe is a powerful and smart tool for machine supervision and real-time storage of large amounts of data with an intuitive and user-friendly interface.



Interactive assistance and guided maintenance are the innovative features of AMe:

- Once the user's tablet frames the machine part requiring assistance, the user can request a video call and will be guided step-by-step by the Italpresse service operator.
- The user is also able to access all the maintenance documentation, available in 3D and PDF and to view step-by-step maintenance procedures in Augmented Reality.



ECO-FIT MODE is the smart system specially designed to save energy. Available on the entire machine range, it reduces electricity consumption by up to 50%.

ECO-FIT MODE PLUS combines the features of ECO-FIT MODE with the advantage of a single-stage pump and a low-inertia motor with encoder feedback increasing energy savings up to 60%. Available for machine sizes up to TF1650 and IP1450.



# Service

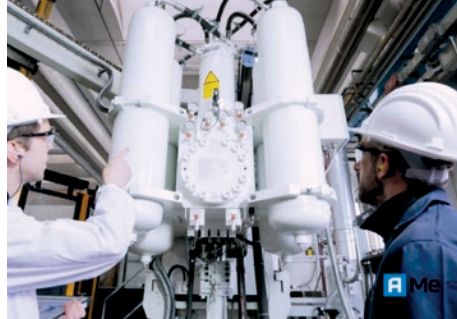

A team of specialist engineers and technicians offers prompt and professional aftersales service to ensure optimum performance and durability of Italtipresse Gauss products, wherever they are.

The Service team can operate promptly on site or via Remote Assistance. A large spare parts warehouse in Italy and several warehouses around the world guarantee rapid delivery of spare parts. Specialist training courses can be provided onsite on your premises, or here at Capriano del Colle. We also provide a range of other services, such as assistance for manufacturing and production processes, to support you in the use and management of our systems.



# Fields of application

## Automotive

Our main field of application is the automotive industry. We supply machines and automatic work cells to almost all the world's major automotive companies and to all major OEM suppliers in the industry.

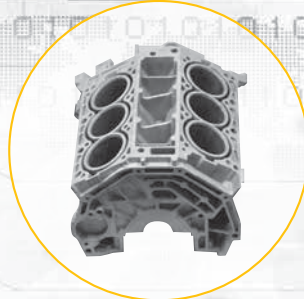

Engine blocks

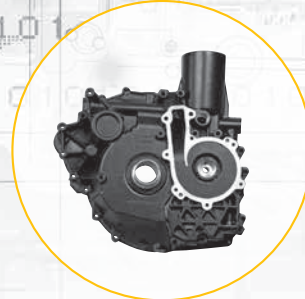

Motor components

- Cylinder heads
- Gearbox
- Oil sump
- Clutch housing
- Steering box
- Turbocharger body
- Engine support
- Intake manifolds



Structural castings



Wheels

- Sterring knuckle
- Suspension arm
- Front and rear brake calipers

## Other industries

Furthermore, we are also suppliers of machines and cells for various industries.



Radiators for household heating



Escalator steps



Chassis and components for electronic devices

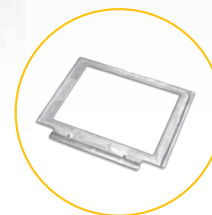

Telecommunication components



Electric motors

[www.italpressegauss.com](http://www.italpressegauss.com)

**Itaipresse Industrie S.p.A.**  
**Gauss Automazione S.p.A.**

Via Trento, 178  
25020 Capriano del Colle (BS) - Italy

T: +39 030 9749300  
F: +39 030 9748213  
E: [info@italpressegauss.com](mailto:info@italpressegauss.com)  
[www.italpressegauss.com](http://www.italpressegauss.com)

**ITALPRESSE | GAUSS**  
A Norican Technology

We are Norican: DISA | Itaipresse Gauss | StrikoWestofen | Wheelabrator  
[www.noricangroup.com](http://www.noricangroup.com)